





Plunger valve 3/2-way direct-acting

- Direct-acting, compact valve with diameter of up to DN 2.5
- Vibration-proof, bolted coil system
- Banjo threaded connection for direct mounting on pneumatic valves
- Explosion proof variants
- Energy-saving variants with Kick and Drop available



Product variants described in the data sheet may differ from the product presentation and description.

Can be combined with

	Type 2518 Cable plug, form A according to DIN EN 175301-803	▶
	Type 1087 Timer, form A according to DIN EN 175301-803	▶
	Type 2509 Cable plug, form A according to DIN EN 175301-803	▶

Type description

Valve 6014 is a direct-acting plunger valve. The stopper and core guide tube are welded together to enhance pressure resistance and leak-tightness. Various seal material combinations are available depending on the application. A Bürkert-specific flange variant (SFB) enables space-saving arrangement of valves on a manifold. Kick and Drop coils are available for the reduction of electrical power consumption during operation.

Table of contents

1. General technical data	4
2. Circuit functions	5
3. Approvals and conformities	5
3.1. General notes	5
3.2. Conformity	5
3.3. Standards	5
3.4. Explosion protection.....	6
3.5. North America (USA/Canada)	6
3.6. Drinking water	7
3.7. Foods and beverages/Hygiene	7
3.8. Others	7
DNV GL classification.....	7
Fire protection on railway vehicles	8
4. Materials	8
4.1. Bürkert resistApp	8
4.2. Material specifications	8
Standard variant.....	8
Banjo variant	9
ATEX/IECEX m cable variant	9
ATEX/IECEX m terminal box variant	10
5. Dimensions	11
5.1. Standard variant.....	11
Pin assignment.....	12
5.2. Banjo variant	12
With 76 mm banjo bolt.....	12
With 60 mm banjo bolt.....	13
5.3. ATEX/IECEX m cable variant	14
5.4. ATEX/IECEX m terminal box variant	15
5.5. ATEX/IECEX ia variant.....	16
5.6. Single manifold	17
5.7. Multiple manifold.....	17
5.8. Manifolds for block mounting.....	18
6. Performance specifications	18
6.1. Power consumption	18
6.2. Utilisation in another circuit function.....	18
6.3. Electrical data explosion-proof variant EEx ia	19
7. Product installation	19
7.1. Installation notes	19
Control for impulse variant with polarity reversal control	19
8. Product accessories	20
8.1. Cable glands for ATEX/IECEX terminal box	20
8.2. Special tool to turn the terminal box	20

9. Ordering information	21
9.1. Bürkert eShop	21
9.2. Bürkert product filter	21
9.3. Bürkert Product Enquiry Form	21
9.4. Ordering chart	22
Standard variant.....	22
Banjo variant	24
ATEX/IECEX m cable variant	25
ATEX/IECEX m terminal box variant	26
ATEX/IECEX ia variant.....	27
9.5. Ordering chart accessories.....	27
Single manifold	27
Multiple manifold.....	27
Cable plug Type 2518, form A according to DIN EN 175301 - 803	27
Cable plug Type 2509, form A according to DIN EN 175301 - 803.....	28
Cable glands for ATEX/IECEX terminal box.....	28

DTS 1000011035 EN Version: AA Status: RL (released | freigegeben | valide) printed: 22.05.2026

1. General technical data

Product properties	
Dimensions	Further information can be found in chapter "5. Dimensions" on page 11.
Material	
Seal	FKM (EPDM on request)
Body	Brass, stainless steel 1.4305/303, polyamide (sub-base)
Coil	Polyamide (epoxy on request)
Manual override	This is an "emergency manual override" which allows manual operation in the event of a fault. (Leakage possible)
Orifice	DN 1.5...DN 2.5
Circuit function	C, D and T Further information can be found in chapter "2. Circuit functions" on page 5.
Thermal insulation class of solenoid coil	Polyamide coil class B Epoxy coil class H
Performance data	
Duty cycle/single valve with block assembly	100 % continuous operation Intermittent operation 60 % (30 min) or with 5 W coil (on request)
Electrical data	
Operating voltage	24 V DC, 24 V 50 Hz, 24 V 60 Hz, 110 V 50 Hz, 120 V 60 Hz, 230 V 50 Hz, 240 V 60 Hz (other voltages on request)
Power consumption	Further information can be found in chapter "6.1. Power consumption" on page 18.
Voltage tolerance	± 10 %
Medium data	
Operating medium	Technical vacuum, neutral gases and liquids (e.g. compressed air, town gas, natural gas, water, hydraulic oil, petrol)
Medium temperature	
With FKM	-10 °C...+100 °C (PA coil), -10 °C...+120 °C (epoxy coil), -40 °C on request
With PTFE/Graphite	-40 °C...+180 °C (further information can be found in chapter "4.1. Bürkert resistApp" on page 8)
With FKM, circuit function B	-10 °C...+100 °C (AC), -10 °C...+120 °C (DC)
Viscosity	Max. 21 mm ² /s
Product connections	
Electrical connection	<ul style="list-style-type: none"> Plug contacts according to DIN EN 175 301 - 803 form A for cable plug Type 2518 ▶. Further information can be found in chapter "Cable plug Type 2518, form A according to DIN EN 175301 - 803" on page 27. Plug contacts according to DIN EN 175 301 - 803 form A for cable plug Type 2509 ▶. Further information can be found in chapter "Cable plug Type 2509, form A according to DIN EN 175301 - 803" on page 28. ATEX/IECEx variant with 3 m moulded cable or terminal box
Port connection	G 1/8, G 1/4, NPT 1/8, NPT 1/4, sub-base (SFB)
Approvals and conformities	
Degree of protection	IP65 with cable plug Type 2518 ▶ NEMA 4X with cable plug Type 2509 ▶ with stainless steel variants
Explosion protection	Further information can be found in chapter "3.4. Explosion protection" on page 6.
North America (USA/Canada)	Further information can be found in chapter "3.5. North America (USA/Canada)" on page 6.
Drinking water	Further information can be found in chapter "3.5. North America (USA/Canada)" on page 6.
Foods and beverages/Hygiene	Further information can be found in chapter "3.7. Foods and beverages/Hygiene" on page 7.
Others	Further information can be found in chapter "3.8. Others" on page 7.
Environment and installation	
Installation position	As required, preferably with actuator upright
Ambient temperature	Max. +55 °C

2. Circuit functions

Symbol	Description
	Circuit function C (CF C) 3/2-way solenoid valve Direct-acting Normally closed
	Circuit function D (CF D) 3/2-way solenoid valve Direct-acting Normally open
	Circuit function T (CF T) 3/2-way solenoid valve Direct-acting Flow direction optional Normally closed

3. Approvals and conformities

3.1. General notes

- The approvals and conformities listed below must be stated when making enquiries. This is the only way to ensure that the product complies with all required specifications.
- Not all available variants can be supplied with the below mentioned approvals or conformities.



3.2. Conformity

In accordance with the Declaration of Conformity, the product is compliant with the EU Directives.



3.3. Standards

The applied standards which are used to demonstrate compliance with the EU Directives are listed in the EU-Type Examination Certificate and/or the EU Declaration of Conformity.

3.4. Explosion protection

Approval	Description								
 	<p>Optional: Explosion protection according to category 2 (zone 1/21)</p> <p>Ex marking of the components according to the following table:</p> <table border="1"> <thead> <tr> <th colspan="2">Coil Type AC10</th> </tr> <tr> <th>Coils with cable outlet</th> <th>Coils with terminal box</th> </tr> </thead> <tbody> <tr> <td> ATEX: EPS 18 ATEX 1232 X II 2G Ex mb IIC T4 Gb II 2D Ex mb IIIC T130 °C Db </td> <td> ATEX: EPS 18 ATEX 1232 X II 2G Ex eb mb IIC T4 Gb II 2D Ex mb tb IIIC T130 °C Db </td> </tr> <tr> <td> IECEX: IECEX EPS 18.0110 X Ex mb IIC T4 Gb Ex mb IIIC T130 °C Db </td> <td> IECEX: IECEX EPS 18.0110 X Ex eb mb IIC T4 Gb Ex mb tb IIIC T130 °C Db </td> </tr> </tbody> </table>	Coil Type AC10		Coils with cable outlet	Coils with terminal box	ATEX: EPS 18 ATEX 1232 X II 2G Ex mb IIC T4 Gb II 2D Ex mb IIIC T130 °C Db	ATEX: EPS 18 ATEX 1232 X II 2G Ex eb mb IIC T4 Gb II 2D Ex mb tb IIIC T130 °C Db	IECEX: IECEX EPS 18.0110 X Ex mb IIC T4 Gb Ex mb IIIC T130 °C Db	IECEX: IECEX EPS 18.0110 X Ex eb mb IIC T4 Gb Ex mb tb IIIC T130 °C Db
	Coil Type AC10								
	Coils with cable outlet	Coils with terminal box							
ATEX: EPS 18 ATEX 1232 X II 2G Ex mb IIC T4 Gb II 2D Ex mb IIIC T130 °C Db	ATEX: EPS 18 ATEX 1232 X II 2G Ex eb mb IIC T4 Gb II 2D Ex mb tb IIIC T130 °C Db								
IECEX: IECEX EPS 18.0110 X Ex mb IIC T4 Gb Ex mb IIIC T130 °C Db	IECEX: IECEX EPS 18.0110 X Ex eb mb IIC T4 Gb Ex mb tb IIIC T130 °C Db								
<p>Coil Type AC10 (Ex-i variant)</p> <p>ATEX: EPS 18 ATEX 1 088 X II 2G Ex ia IIC T6/T4 Gb II 2D Ex ia IIIC T135 °C Db</p> <p>IECEX: IECEX EPS 18.0038 X Ex ia IIC T6/T4 Gb Ex ia IIIC T135 °C Db</p>									
<p>Optional: Explosion protection according to category 3 (zone 2/22)</p> <p>Ex marking of the components according to the following table:</p> <table border="1"> <thead> <tr> <th colspan="2">Coil Type AC10</th> </tr> <tr> <th colspan="2">Coil with plug contacts form A and cable plug Type 2509</th> </tr> </thead> <tbody> <tr> <td> ATEX: EPS 21 ATEX 1234 X II 3G Ex ec IIC T4 Gc II 3D Ex tc IIIC T135 °C Dc </td> <td> IECEX: IECEX EPS 21.0078X Ex ec IIC T4 Gc Ex tc IIIC T135 °C Dc </td> </tr> </tbody> </table>	Coil Type AC10		Coil with plug contacts form A and cable plug Type 2509		ATEX: EPS 21 ATEX 1234 X II 3G Ex ec IIC T4 Gc II 3D Ex tc IIIC T135 °C Dc	IECEX: IECEX EPS 21.0078X Ex ec IIC T4 Gc Ex tc IIIC T135 °C Dc			
Coil Type AC10									
Coil with plug contacts form A and cable plug Type 2509									
ATEX: EPS 21 ATEX 1234 X II 3G Ex ec IIC T4 Gc II 3D Ex tc IIIC T135 °C Dc	IECEX: IECEX EPS 21.0078X Ex ec IIC T4 Gc Ex tc IIIC T135 °C Dc								

3.5. North America (USA/Canada)

Approval	Description
	<p>Optional: UL Listed for the USA (valid for valves)</p> <p>The valves are UL Listed for the USA according to:</p> <ul style="list-style-type: none"> UL 429 (electrically operated valves)
	<p>Optional: UL Hazardous Locations – Explosion Protection (valid for coils)</p> <p>UL Listed for Hazardous Locations for USA and Canada</p> <p>Class I, Zone 1 Class I, Division 2, Group A, B, C and D Class II + III, Division 2, Group F and G</p>

DTS 1000011035 EN Version: AA Status: RL (released | freigegeben | valide) printed: 22.05.2026

Approval	Description
	Optional: UL Recognized for the USA (valid for valves) The valves are UL Recognized for the USA according to: <ul style="list-style-type: none"> UL 429 (electrically operated valves)
	Optional: CSA for Canada (valid for valves) The valves are CSA approved for Canada according to: <ul style="list-style-type: none"> CSA 139 (electrically operated valves)
	Optional: FM (Factory Mutual) – Explosion Protection (valid for coils) FM for Hazardous Locations for USA and Canada Class I, Zone 1 Class I, Division 1, Groups A, B, C and D Class II + III, Division 1, Groups E, F and G
CRN	Canadian Registration Number (CRN) – Technical Standards and Safety Act, Boilers and Pressure Vessels Regulation, and CSA Standard B51 The product fittings comply with all of the requirements of ASME Section B31.3 (Process Piping). Registration number Canada: 0C2430.C R2

3.6. Drinking water

Conformity	Description
	Suitable for use in drinking water applications The materials comply with the assessment principles (UBA) for materials in contact with drinking water (TrinkwasserV). Brass body/Stainless steel body: PF39: Suitable for products with a maximum temperature of + 85 °C (hot water)

3.7. Foods and beverages/Hygiene

Conformity	Description
FDA	FDA – Code of Federal Regulations (valid for the variable code PL02, PL03) All wetted materials are compliant with the Code of Federal Regulations published by the FDA (Food and Drug Administration, USA) according to the manufacturer’s declaration.
USP	United States Pharmacopeial Convention (USP) (valid for the variable code PL04) All wetted materials are biocompatible according to the manufacturer’s declaration.
	EC Regulation 1935/2004 of the European Parliament and of the Council (valid for the variable code PL01, PL02) All wetted materials are compliant with EC Regulation 1935/2004/EC according to the manufacturer’s declaration.

3.8. Others

DNV GL classification

Approval	Description
	DNV GL classification – Ships, offshore units, and high speed and light craft The products are accepted for installation on all vessels classed by DNV GL.

DTS 1000011035 EN Version: AA Status: RL (released | freigegeben | valide) printed: 22.05.2026

Fire protection on railway vehicles

Approval	Description
DIN EN 45545	<p>Optional: Fire protection on railway vehicles in accordance with DIN EN 45545 applicable parts 2 and 5: requirements for fire behaviour of materials and components</p> <p>The products comply with the fire protection requirements in accordance with applicable parts 2 and 5 of DIN EN 45545 for use in the interior of railway vehicles for operating classes 1 - 3 (OC1 - 3) in conjunction with hazard levels 1 - 2 (HL1 - 2) in accordance with the manufacturer's declaration.</p>

4. Materials

4.1. Bürkert resistApp

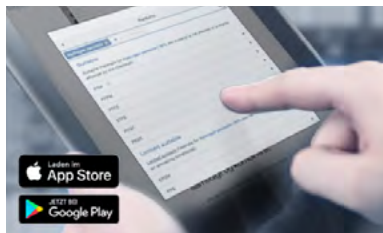

Bürkert resistApp – Chemical resistance chart

You want to ensure the reliability and durability of the materials in your individual application case? Verify your combination of media and materials on our website or in our resistApp.

[Start chemical resistance check](#)

4.2. Material specifications

Standard variant

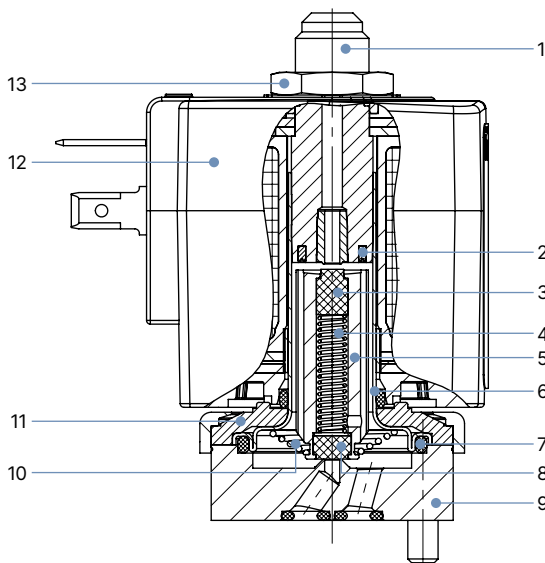

No.	Element	Material
1	Stopper	Stainless steel 1.4105/430F
2	Shading ring	Cu (brass variant) Ag (stainless steel variant)
3	Plunger seal	FKM
4	Spring	Stainless steel 1.4310/301
5	Magnetic core	Stainless steel 1.4105/430F
6	Core guide tube	Stainless steel 1.4303/305/308
7	O-ring	FKM
8	Plunger seal	FKM
9	Valve body	Brass Stainless steel 1.4305/303 Stainless steel 1.4401/316
10	Spring	Stainless steel 1.4310/301
11	Sub-base	Steel, surface finish thick-film passivated (brass variant) Stainless steel 1.4301/304 (stainless steel variant)
12	Coil	PA (Polyamide) Epoxy (High temperature variant)
13	Nut	Steel, surface finish thick-film passivated (brass variant) Stainless steel 1.4305/303 PTFE coated (stainless steel variant)

DTS 1000011035 EN Version: AA Status: RL (released | freigegeben | valide) printed: 22.05.2026

Banjo variant

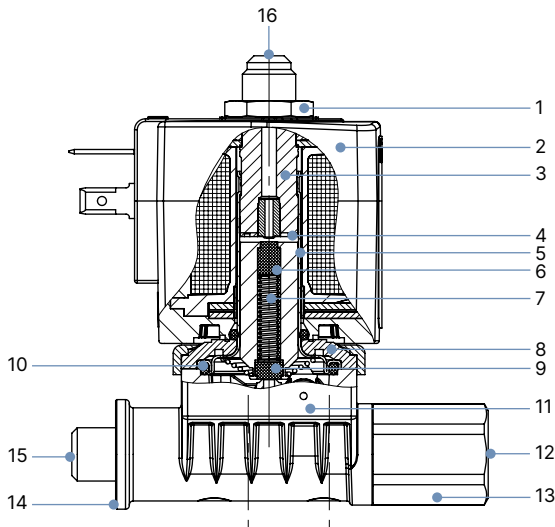

No.	Element	Material
1	Nut	Steel, surface finish thick-film passivated (brass variant) Stainless steel 1.4305/303 PTFE coated (stainless steel variant)
2	Coil	PA (Polyamide) Epoxy (High temperature variant)
3	Stopper	Stainless steel 1.4105/430F
4	Shading ring	Cu (brass variant) Ag (stainless steel variant)
5	Core guide tube	Stainless steel 1.4303/305/308
6	Magnetic core	Stainless steel 1.4105/430F
7	Spring	Stainless steel 1.4310/301
8	Sub-base	Steel, surface finish thick-film passivated (brass variant) Stainless steel 1.4301/304 (stainless steel variant)
9	Plunger seal	FKM
10	O-ring	FKM
11	Valve body	PPS
12	Pressure connection P	-
13	Screw	Brass/Stainless steel 1.4301/304
14	O-ring	FKM
15	Pressure connection A	-
16	R connection	-

ATEX/IECEx m cable variant

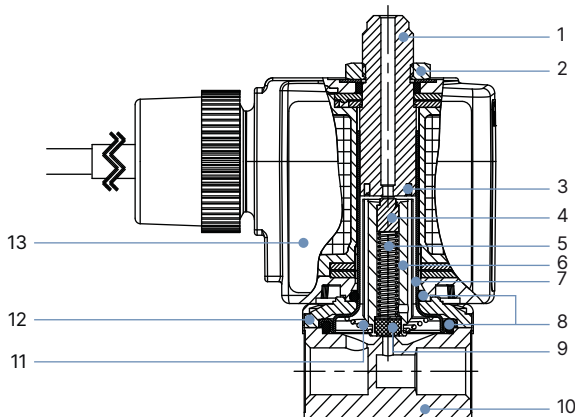

No.	Element	Material
1	Stopper	Stainless steel 1.4105/430F
2	Nut	Steel, surface finish thick-film passivated (brass variant) Stainless steel 1.4305/303 PTFE coated (stainless steel variant)
3	Shading ring	Cu (brass variant) Ag (stainless steel variant)
4	Plunger seal	FKM
5	Spring	Stainless steel 1.4310/301
6	Magnetic core	Stainless steel 1.4105/430F
7	Core guide tube	Stainless steel 1.4303/305/308
8	O-ring	FKM
9	Plunger seal	FKM
10	Valve body	Brass Stainless steel 1.4305/303 Stainless steel 1.4401/316
11	Spring	Stainless steel 1.4310/301
12	Sub-base	Steel, surface finish thick-film passivated (brass variant) Stainless steel 1.4301/304 (stainless steel variant)
13	Coil	Epoxy

DTS 1000011035 EN Version: AA Status: RL (released | freigegeben | valide) printed: 22.05.2026

ATEX/IECEx m terminal box variant

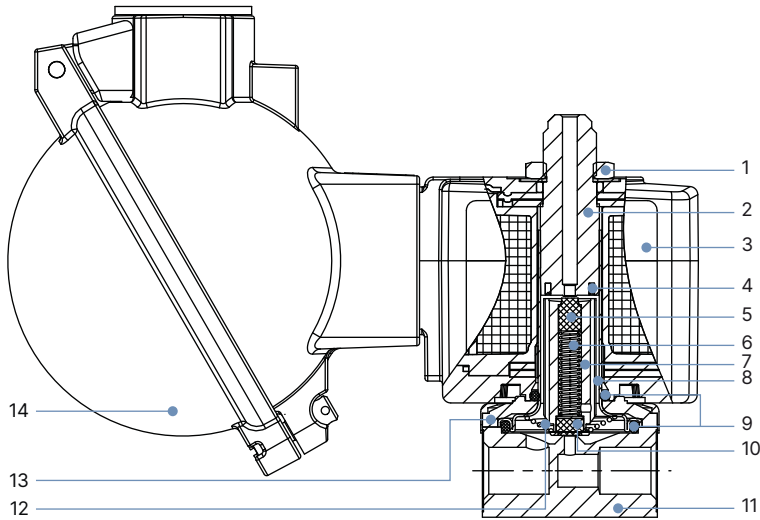

No.	Element	Material
1	Nut	Steel, surface finish thick-film passivated (brass variant) Stainless steel 1.4305/303 PTFE coated (stainless steel variant)
2	Stopper	Stainless steel 1.4105/430F
3	Coil	Epoxy
4	Shading ring	Cu (brass variant) Ag (stainless steel variant)
5	Plunger seal	FKM
6	Spring	Stainless steel 1.4310/301
7	Magnetic core	Stainless steel 1.4105/430F
8	Core guide tube	Stainless steel 1.4303/305/308
9	O-ring	FKM
10	Plunger seal	FKM
11	Valve body	Brass Stainless steel 1.4305/303 (G 1/8) Stainless steel 1.4401/316 (G 1/4)
12	Spring	Stainless steel 1.4310/301
13	Sub-base	Steel, surface finish thick-film passivated (brass variant) Stainless steel 1.4301/304 (stainless steel variant)
14	Terminal box	Aluminium

DTS 1000011035 EN Version: AA Status: RL (released | freigegeben | valide) printed: 22.05.2026

5. Dimensions

5.1. Standard variant

Note:

Dimensions in mm

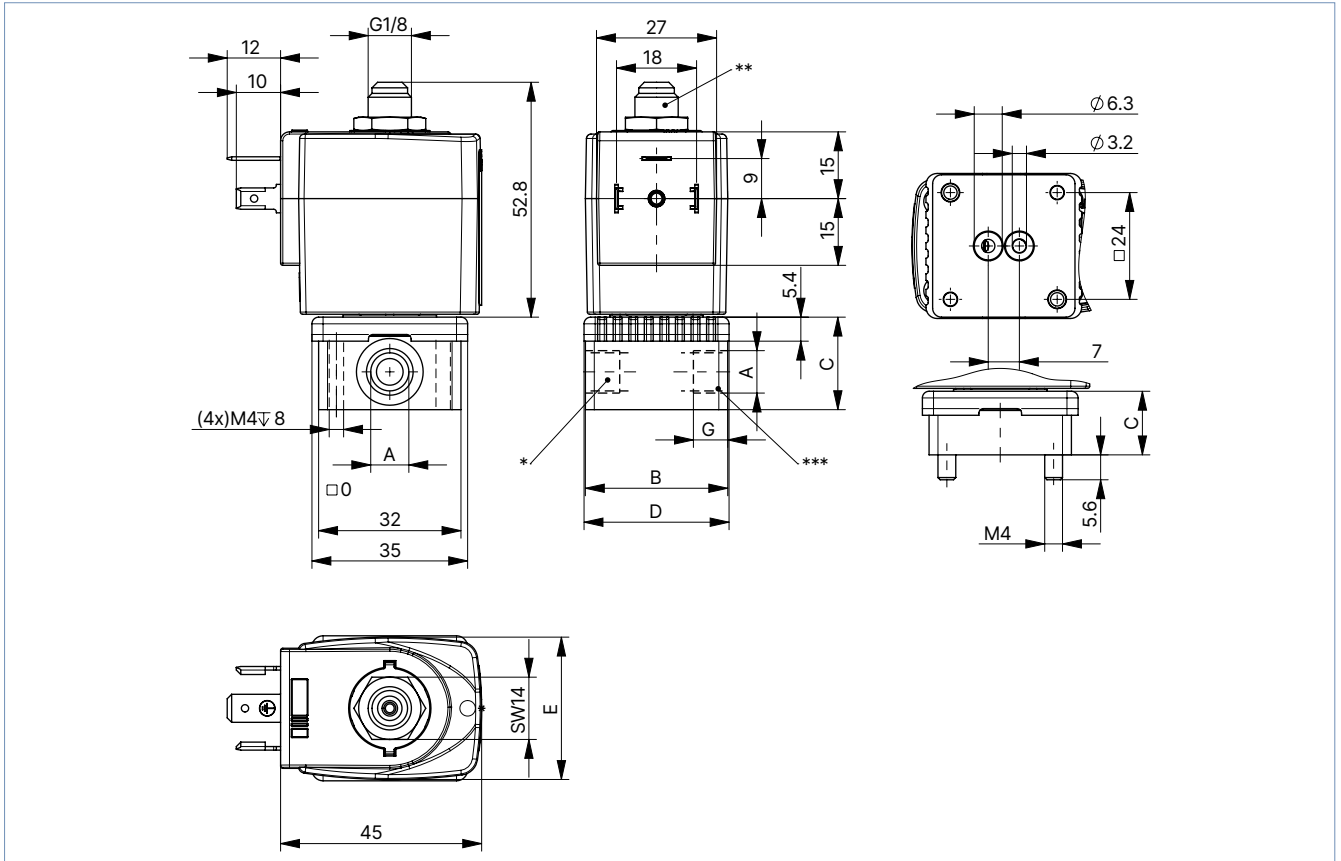

Port connection	A [inch]	B [mm]	C [mm]	D [mm]	G [mm]
Threaded without manual override	G 1/8	32	20.8	32.6	8
	G 1/4	46	26.8	49	12
Threaded with manual override	G 1/8	32	20.8	32.6	8
	G 1/4	46	26.8	49	12
Sub-base	-	32	14.3	32.6	-

Coil size	E [mm]	F [mm]
5	32	45
6	40	51

Pin assignment

For the positions marked with *, ** or *** in the drawing, the connections are marked with the letters shown in the table above, depending on the circuit function. Unused circuit functions A or B connections will be closed off with a blanking plug or cap nut.

Circuit function	Connection Type		
	*	**	***
A	P	blank off	A
B	blank off	B	P
C	P	R	A
D	R	P	B
T	P	R	A

5.2. Banjo variant

With 76 mm banjo bolt

Note:

Dimensions in mm

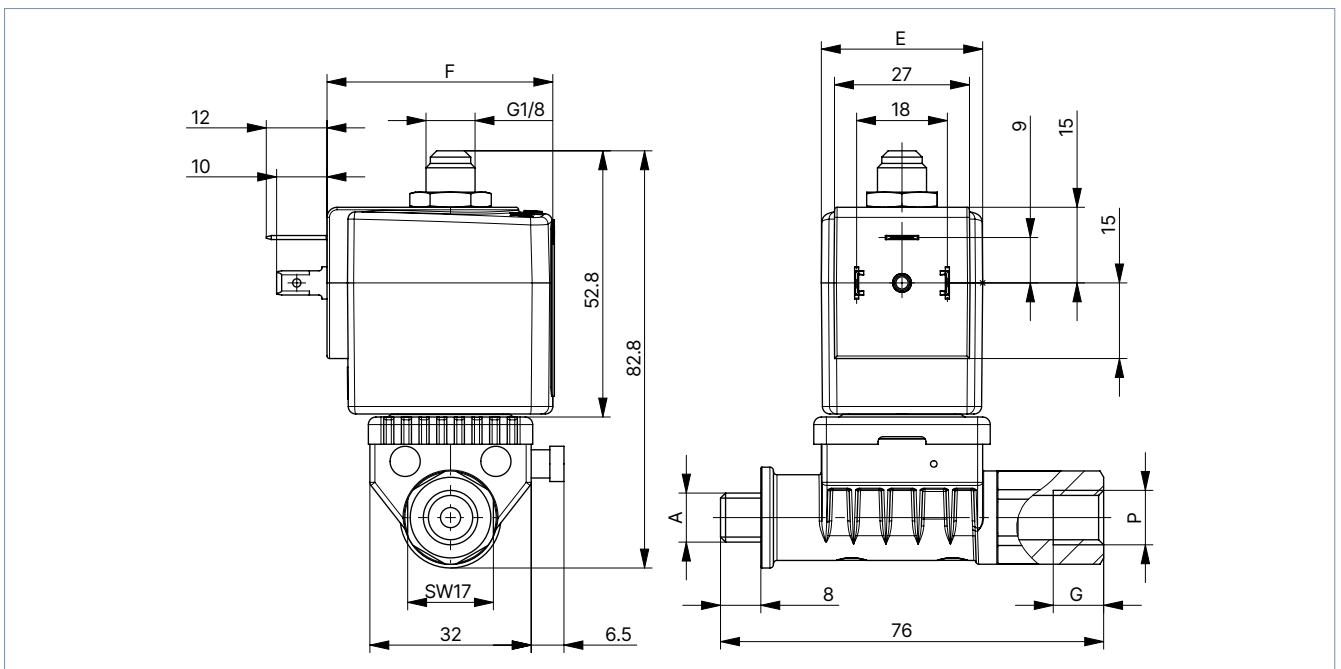

Variant	A	P	G
	[inch]	[inch]	[mm]
BJ02	G 1/4	G 1/4	10
BJ03	G 1/8	NPT 1/4	
BJ04	G 1/4	NPT 1/4	
BJ05	G 1/8	G 1/4	
BJ07	G 1/8	NPT 1/8	

Coil size	E	F
	[mm]	[mm]
5	32	45
6	40	51

DTS 1000011035 EN Version: AA Status: RL (released | freigegeben | valide) printed: 22.05.2026

With 60 mm banjo bolt

Note:

Dimensions in mm

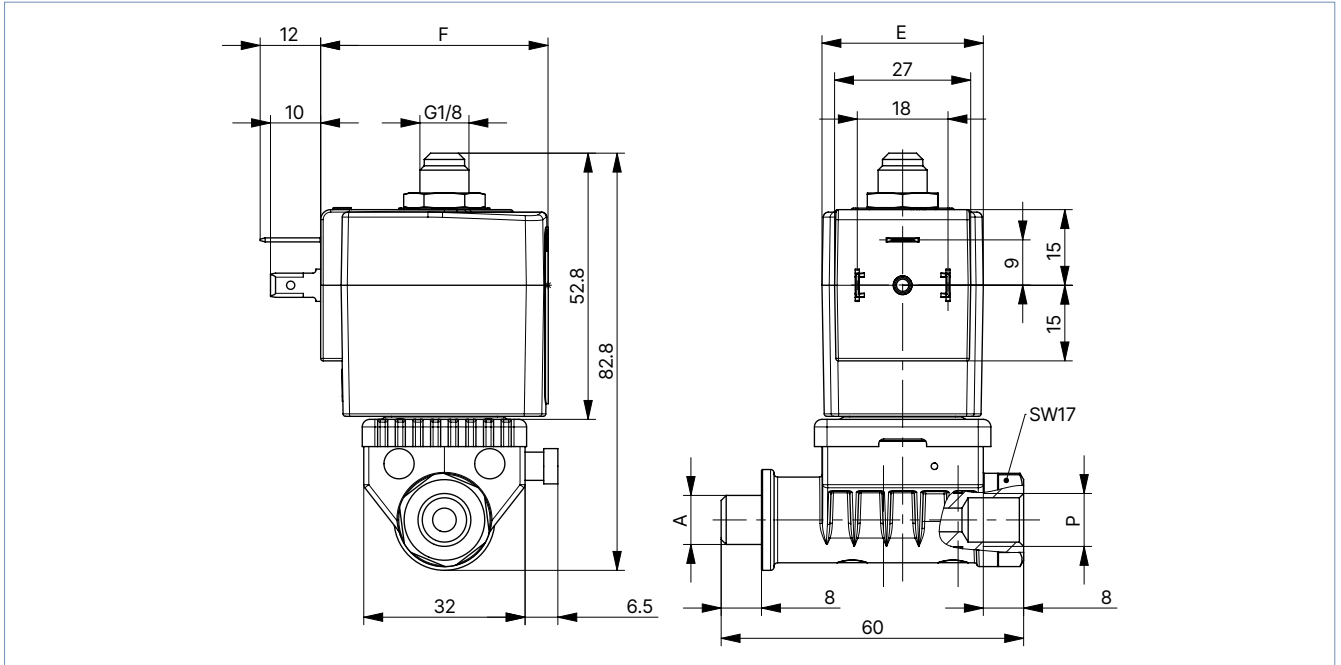

Variant	A	P
	[inch]	[inch]
BJ01	G 1/8	G 1/8
BJ06	G 1/4	G 1/8

Coil size	E	F
	[mm]	[mm]
5	32	45
6	40	51

DTS 1000011035 EN Version: AA Status: RL (released | freigegeben | valide) printed: 22.05.2026

5.3. ATEX/IECEx m cable variant

Note:

Dimensions in mm

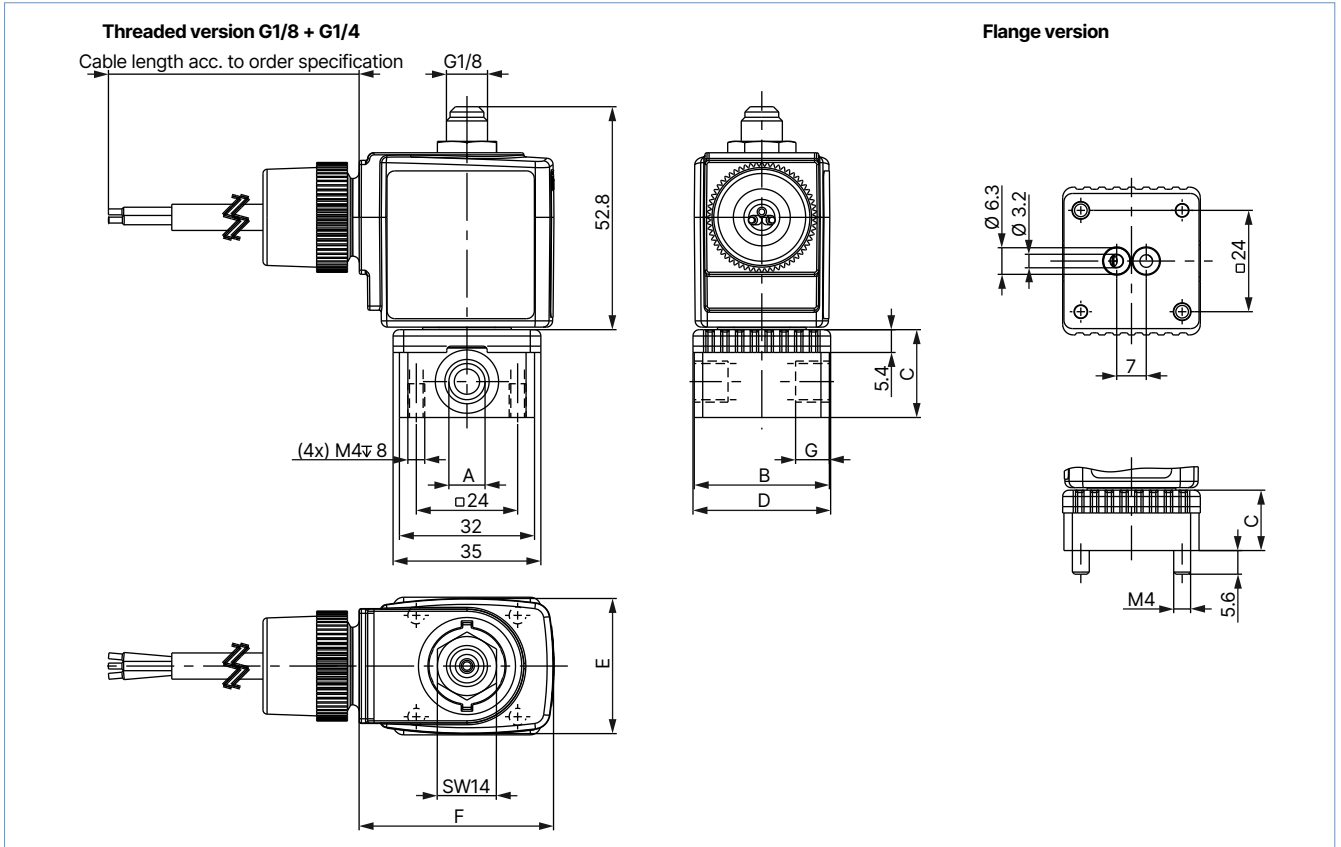

Port connection	A	B	C	D	G
	[inch]	[mm]	[mm]	[mm]	[mm]
Threaded variant	G 1/8	32	20.8	32.6	8
	G 1/4	46	26.8	49	12
Sub-base variant	-	32	14.3	32.6	-

Coil size	E	F
	[mm]	[mm]
5	32	46
6	40	52

DTS 1000011035 EN Version: AA Status: RL (released | freigegeben | valide) printed: 22.05.2026

5.4. ATEX/IECEx m terminal box variant

Note:

Dimensions in mm

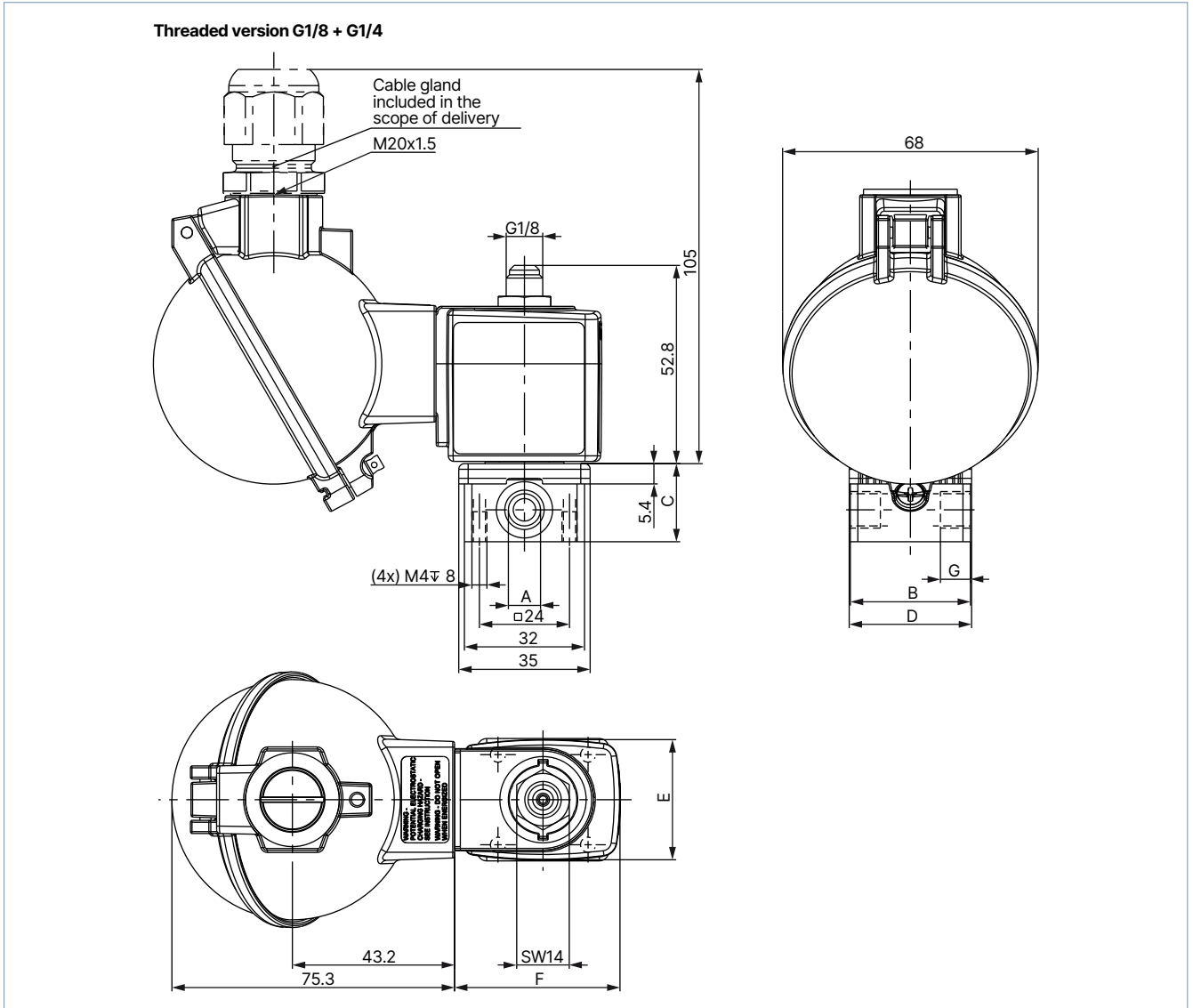

Port connection	A	B	C	D	G
	[inch]	[mm]	[mm]	[mm]	[mm]
Threaded variant	G 1/8	32	20.8	32.6	8
	G 1/4	46	26.8	49	12
Sub-base variant	-	32	14.3	32.6	-

Coil size	E	F
	[mm]	[mm]
5	32	44
6	40	51

DTS 1000011035 EN Version: AA Status: RL (released | freigegeben | valide) printed: 22.05.2026

5.5. ATEX/IECEx ia variant

Note:

- Dimensions in mm
- Further information about electrical data can be found in chapter “6.3. Electrical data explosion-proof variant EEx ia” on page 19.

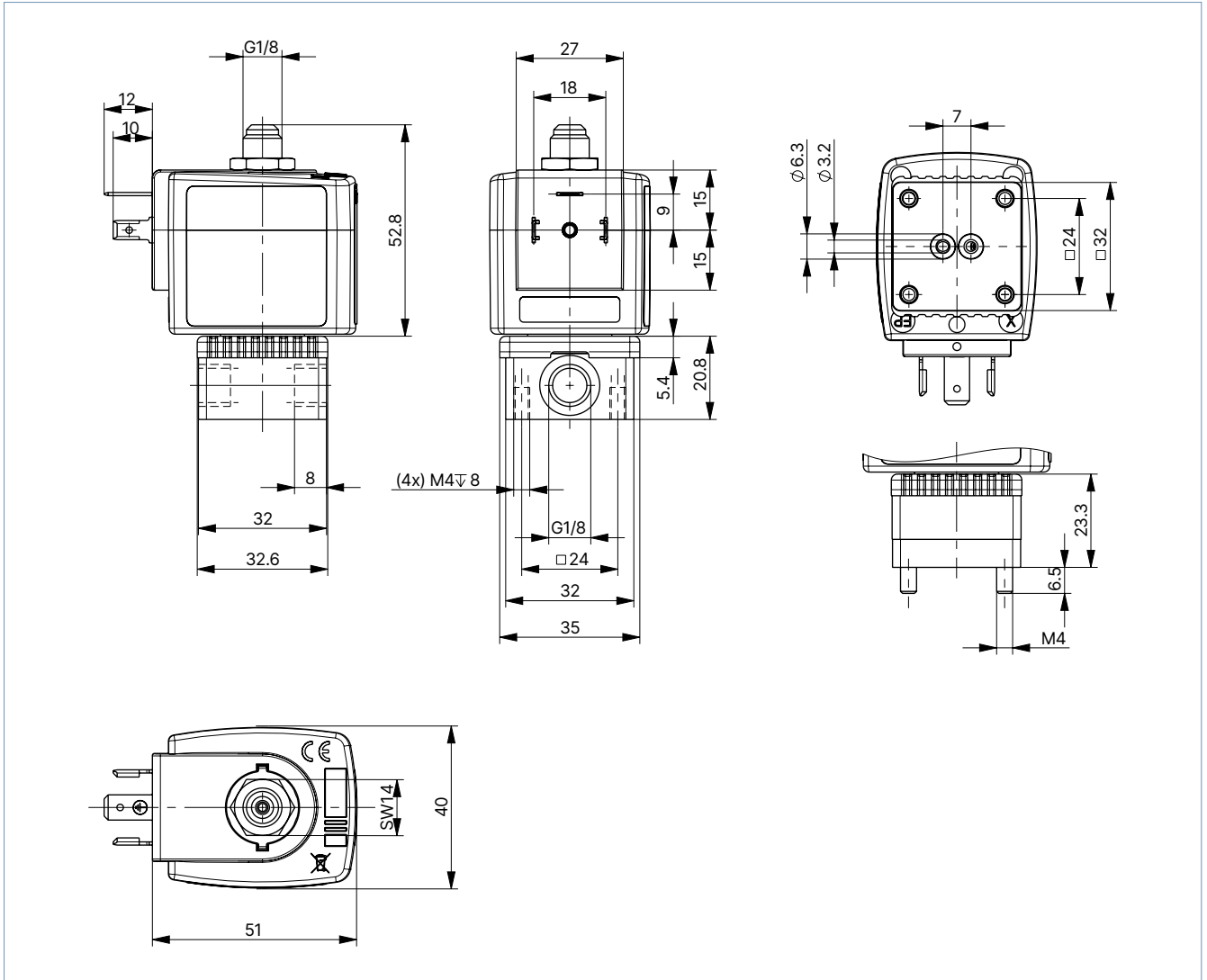

DTS 1000011035 EN Version: AA Status: RL (released | freigegeben | valide) printed: 22.05.2026

5.6. Single manifold

Note:

- Dimensions in mm
- Further information about the installation of manifolds can be found in chapter "5.8. Manifolds for block mounting" on page 18.

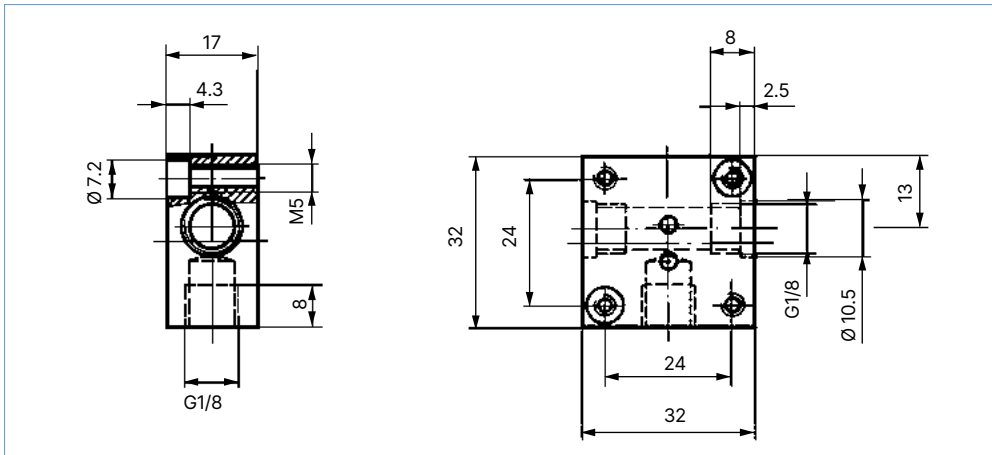

5.7. Multiple manifold

Note:

- Dimensions in mm
- The manifold is only possible with coil size 5.
- Brass or stainless steel manifolds is available on request.

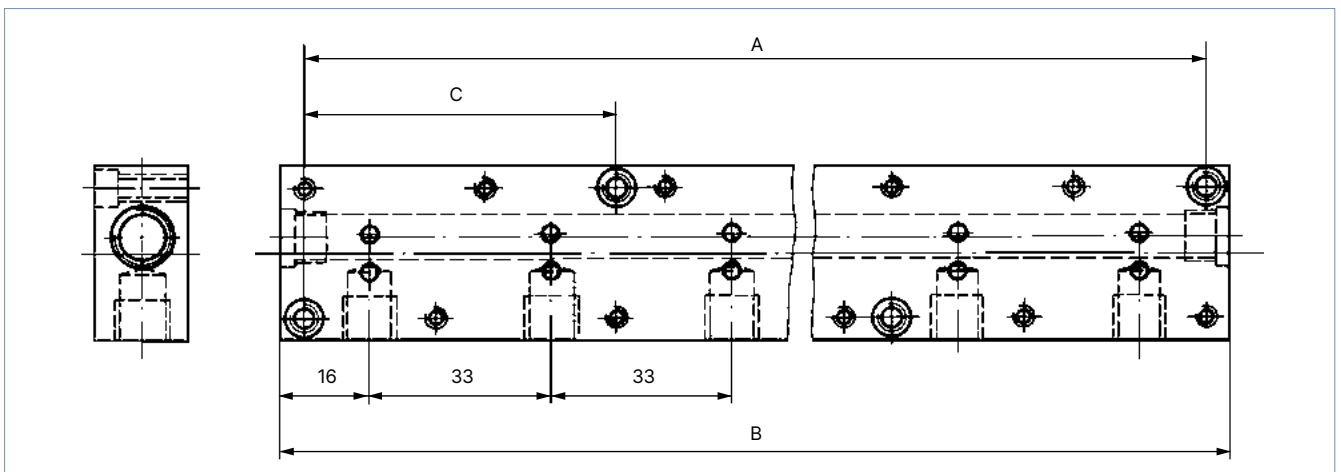

Accessory parts	Number of valve positions	Hole spacing A		Total length B		Hole spacing C		Article no.
		[mm]	[inch]	[mm]	[inch]	[mm]	[inch]	
Multiple manifold (aluminium)	2	57	2.24	65	2.56	-	-	005023
	3	90	3.54	98	3.86	-	-	005286
	4	123	4.84	131	5.16	-	-	005287
	5	156	6.14	164	6.46	57	2.24	005035
	6	189	7.44	197	7.76	57	2.24	005038
	8	255	10	263	10.35	90	3.54	005386
	10	321	12.64	329	12.95	90	3.54	005764
Single manifold (aluminium)								005020
Plug nipple with O-rings for connecting manifolds								005040
Covering plate with screws and O-ring for closing off unused valve positions								005630

DTS 1000011035 EN Version: AA Status: RL (released | freigegeben | valide) printed: 22.05.2026

5.8. Manifolds for block mounting

Note:

- Close open ports for valves that are not required with cover plates (see accessories).
- Fasten the manifolds to a standard rail.
- Refer to chapter "5.7. Multiple manifold" on page 17 for more information about the dimensions.

With manifold mounting, please comply with the permissible duty cycle (5 W variants with 100 % continuous rating or 8 W variant with 60 % duty cycle). The pressure port for the manifold is designated with P (R), and the outlet port with A (B). Only connect together ports with the same designation.

2/2-way valves of Type 6013 can be operated together on a manifold with 3/2-way valves of Type 6014, circuit function C (not D or T!) if the operating pressures matches according to the rating plates. The manifolds can also be expanded if the valve functions are taken into consideration. Connector nipples with O-rings are used to connect the P (R) ports.

6. Performance specifications

6.1. Power consumption

Orifice [mm]	Coil power [W]	Power consumption		Response times ¹⁾	
		Inrush AC [VA]	Hold AC [VA/W]	Opening [ms]	Closing [ms]
1.5	8 W AC or 8 W DC (9)	24	8	10...15	15...20
2.0	8 W AC or 8 W DC (9)			10...15	15...20
2.5	8 W AC or 8 W DC (9)			15...20	10...22

1.) Measurement at +20 °C, 6 bar at the valve outlet, opening: pressure build-up 0...90 %, closing: pressure reduction 100...10 %

6.2. Utilisation in another circuit function

The valves are equipped with different springs for specific circuit functions. When used with other circuit functions, the permissible operating pressure changes according to the following table.

Standard variant		Max. operating pressure [bar] for valve application in circuit function				
DN	Circuit function	A	B	C	D	T
1.5	C	16	22	16	2	2
	D	2	2.5	2	16	2
	T	10	16	10	6	6
2.0	C	10	14	10	1	1
	D	1	1.5	1	10	1
	T	6	10	6	4	4
2.5	C	6	9	6	0.7	0.7
	D	0.7	1	0.7	6	0.7
	T	3.5	6	3.5	2.5	2.5

6.3. Electrical data explosion-proof variant EEx ia

Note:

- The valve is intended for operation at 24 V/DC outputs via the intermedia switching of a corresponding intrinsically safe operating resource (isolating module or barrier).
- Ignition protection class: EEx ia IIC T6 according to PTB-No. Ex- 96.D.2010
- Further information can be found in the **operating instructions EPS 18 ATEX 1088X** ▶.

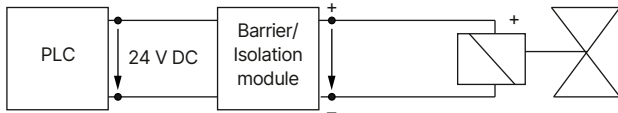

7. Product installation

7.1. Installation notes

Control for impulse variant with polarity reversal control

Note:

- Please use only the cable plug without electrical wiring for the impulse variant.
- Pulse duration at least 50 ms

Polarity (is marked on the coil with a label)	Features	Terminal connections
- switch ON +	valve open	(+) on terminal 2 and (-) on terminal 1 (see below)
+ switch OFF -	valve closed	(+) on terminal 1 and (-) on terminal 2 (see below)

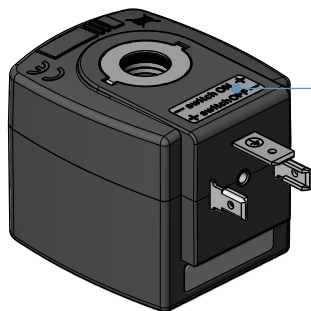

Polarity is marked on the coil with a label:
- switch ON +
+ switch OFF -

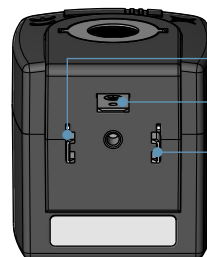



1
Protective conductor port
2

8. Product accessories

8.1. Cable glands for ATEX/IECEX terminal box

Note:

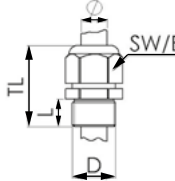
A polyamide cable gland is included in the scope of delivery. A nickel-plated brass variant can be ordered for a surcharge, see [“Cable glands for ATEX/IECEX terminal box” on page 28.](#)

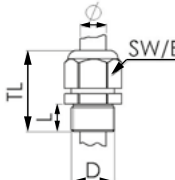
Description	Ex approval		Dimensions										
	Certification	Identification											
Ex cable gland, nickel-plated brass, 6...13 mm 	PTB 04 ATEX 1112 X, IECEX PTB 13.0027X	II 2 G Ex e IIC Gb, II 2 D Ex tb IIIC Db IP68	 <table border="1"> <tr><td>TL</td><td>29...37 mm</td></tr> <tr><td>L</td><td>6 mm</td></tr> <tr><td>D</td><td>20 mm</td></tr> <tr><td>SW</td><td>24 mm</td></tr> <tr><td>E</td><td>27 mm</td></tr> </table>	TL	29...37 mm	L	6 mm	D	20 mm	SW	24 mm	E	27 mm
TL	29...37 mm												
L	6 mm												
D	20 mm												
SW	24 mm												
E	27 mm												
Ex cable gland, polyamide, 7...13 mm 	PTB 13 ATEX 1015 X, IECEX PTB 13.0034X	II 2 G Ex e IIC Gb, II 2 D Ex tb IIIC Db IP68	 <table border="1"> <tr><td>TL</td><td>36...45 mm</td></tr> <tr><td>L</td><td>10 mm</td></tr> <tr><td>D</td><td>20 mm</td></tr> <tr><td>SW</td><td>24 mm</td></tr> <tr><td>E</td><td>28 mm</td></tr> </table>	TL	36...45 mm	L	10 mm	D	20 mm	SW	24 mm	E	28 mm
TL	36...45 mm												
L	10 mm												
D	20 mm												
SW	24 mm												
E	28 mm												

8.2. Special tool to turn the terminal box

Note:

This special tool is not included in the scope of delivery of the valve, see [“Cable glands for ATEX/IECEX terminal box” on page 28.](#)

Description	Components of the set
Set SC02-AC10 	<ul style="list-style-type: none"> • Special tool • Service manual

DTS 1000011035 EN Version: AA Status: RL (released | freigegeben | valide) printed: 22.05.2026

9. Ordering information

9.1. Bürkert eShop



Bürkert eShop – Easy ordering and quick delivery

You want to find your desired Bürkert product or spare part quickly and order directly? Our online shop is available for you 24/7. Sign up and enjoy all the benefits.

[Order online now](#)

9.2. Bürkert product filter



Bürkert product filter – Get quickly to the right product

You want to select products comfortably based on your technical requirements? Use the Bürkert product filter and find suitable articles for your application quickly and easily.

[Try out our product filter](#)

9.3. Bürkert Product Enquiry Form

Note:

Please see our Product Enquiry Form for a full explanation of our specification key.

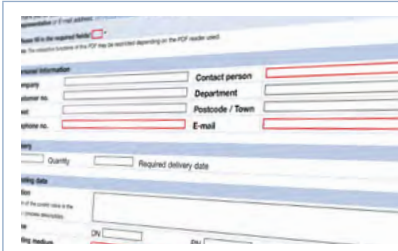

Bürkert Product Enquiry Form – Your enquiry quickly and compactly

Would you like to make a specific product enquiry based on your technical requirements? Use our Product Enquiry Form for this purpose. There you will find all the relevant information for your Bürkert contact. This will enable us to provide you with the best possible advice.

[Fill out the form now](#)

DTS 1000011035 EN Version: AA Status: RL (released | freigegeben | valide) printed: 22.05.2026

9.4. Ordering chart

Standard variant

Note:

Please note that the cable plug has to be ordered separately, see "9.5. Ordering chart accessories" on page 27 or separate datasheet Type 2518 ▶

Circuit function	Port connection	Orifice [mm]	K _v value water ¹⁾ [m ³ /h]	Coil power [W]	Pressure range ²⁾ [bar]	Article no.		
						024/DC [V/Hz]	024/50 [V/Hz]	230/50 [V/Hz]
Threaded variant with FKM seal, (class B)								
Brass body								
CF C 3/2-way solenoid valve Direct-acting Normally closed 	G 1/8	1.5	0.07	8	0...16	125329 ☒	125331 ☒	125332 ☒
	G 1/8	2.0	0.11	8	0...10	125333 ☒	125334 ☒	125336 ☒
	G 1/4		0.11	8	0...10	125348 ☒	126138 ☒	126140 ☒
	G 1/8	2.5	0.16	8	0...6	125341 ☒	125340 ☒	125342 ☒
	G 1/4		0.16	8	0...6	126142 ☒	126143 ☒	126145 ☒
CF D 3/2-way solenoid valve Direct-acting Normally open 	G 1/8	1.5	0.07	8	0...16	126195 ☒	126196 ☒	125355 ☒
	G 1/8	2.0	0.11	8	0...10	125357 ☒	125358 ☒	125360 ☒
	G 1/4		0.11	8	0...10	126198 ☒	126199 ☒	126201 ☒
	G 1/8	2.5	0.16	8	0...6	125363 ☒	126202 ☒	126204 ☒
	G 1/4		0.16	8	0...6	126205 ☒	126206 ☒	126208 ☒
CFT 3/2-way solenoid valve Direct-acting Flow direction optional Normally closed 	G 1/8	1.5	0.07	8	0...7	126150 ☒	126151 ☒	126153 ☒
With manual override								
CF C 3/2-way solenoid valve Direct-acting Normally closed 	G 1/8	2.0	0.11	8	0...10	125337 ☒	125338 ☒	125339 ☒
	G 1/4		0.11	8	0...10	125349 ☒	126147 ☒	126149 ☒
CF D 3/2-way solenoid valve Direct-acting Normally open 	G 1/8	2.0	0.11	8	0...10	126209 ☒	125361 ☒	126211 ☒
	G 1/4		0.11	8	0...10	126212 ☒	126213 ☒	126215 ☒
Stainless steel body								
CF C 3/2-way solenoid valve Direct-acting Normally closed 	G 1/8	1.5	0.07	8	0...16	126216 ☒	126217 ☒	126219 ☒
	G 1/8	2.0	0.11	8	0...10	126220 ☒	126221 ☒	126223 ☒
	G 1/4	2.0	0.11	8	0...10	126224 ☒	126225 ☒	126227 ☒

DTS 1000011035 EN Version: AA Status: RL (released | freigegeben | valide) printed: 22.05.2026

Circuit function	Port connection	Orifice	K _v value water ¹⁾	Coil power	Pressure range ²⁾	Article no.		
		[mm]	[m ³ /h]			[W]	[bar]	024/DC [V/Hz]
CF T 3/2-way solenoid valve Direct-acting Flow direction optional Normally closed 	G 1/8	1.5	0.07	8	0...7	126228 ☒	126229 ☒	126231 ☒

1.) Measurement at + 20 °C, 1 bar²⁾ at the valve inlet and free outlet
 2.) Pressure data: overpressure to atmospheric pressure

Note:

Please note that the cable plug must be ordered separately, see **"9.5. Ordering chart accessories"** on page 27 or separate datasheet **Type 2518** ▶

Circuit function	Orifice	K _v value water ¹⁾	Coil power	Pressure range ²⁾	Article no.		
	[mm]	[m ³ /h]			[W]	[bar]	024/DC [V/Hz]
Sub-base body (SFB) with FKM seal (class B)							
Brass body							
CF C 3/2-way solenoid valve Direct-acting Normally closed 	1.5	0.07	8	0...16	126154 ☒	126155 ☒	125366 ☒
	2.0	0.11	8	0...10	125367 ☒	125368 ☒	125370 ☒
CF D 3/2-way solenoid valve Direct-acting Normally open 	2.0	0.11	8	0...10	126161 ☒	126162 ☒	125383 ☒
With manual override							
CF C 3/2-way solenoid valve Direct-acting Normally closed 	1.5	0.07	5	0...10	126403 ☒	126404 ☒	126406 ☒
	1.5	0.07	8	0...16	126157 ☒	126158 ☒	126160 ☒
	2.0	0.11	5	0...6	126407 ☒	126408 ☒	126410 ☒
	2.0	0.11	8	0...10	125371 ☒	125372 ☒	125374 ☒
Polyamide body							
CF C 3/2-way solenoid valve Direct-acting Normally closed 	1.5	0.07	5	0...10	126390 ☒	126391 ☒	126393 ☒

DTS 1000011035 EN Version: AA Status: RL (released | freigegeben | valide) printed: 22.05.2026

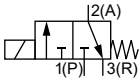
Circuit function	Orifice [mm]	K _v value water ¹⁾ [m ³ /h]	Coil power [W]	Pressure range ²⁾ [bar]	Article no.		
					024/DC [V/Hz]	024/50 [V/Hz]	230/50 [V/Hz]
With manual override							
CF C 3/2-way solenoid valve Direct-acting Normally closed 	1.5	0.07	5	0...10	126396 ☒	126397 ☒	126399 ☒

1.) Measurement at + 20 °C, 1 bar²⁾ at the valve inlet and free outlet

2.) Pressure data: overpressure to atmospheric pressure

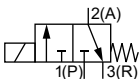
Circuit function	Port connection	Orifice [mm]	K _v value water ¹⁾ [m ³ /h]	Power consumption DC (warm/cold coil) [W]	Pressure range ²⁾ [bar]	Article no.		
						012/DC [V/Hz]	024/DC [V/Hz]	
Impulse variant with FKM seal and brass body (class H)								
CF C 3/2-way solenoid valve Direct-acting Normally closed 	Threaded port	G 1/8	1.5	0.07	7	0...16	209280 ☒	209284 ☒
				2.0	0.11	7	0...10	209281 ☒
	Sub-base {SFB}	Sub-base {SFB}	1.5	0.07	7	0...16	209278 ☒	209282 ☒
				2.0	0.11	7	0...10	209279 ☒

1.) Measurement at + 20 °C, 1 bar²⁾ at the valve inlet and free outlet

2.) Pressure data: overpressure to atmospheric pressure

Banjo variant

Note:

- Please note that the cable plug must be ordered separately, see **"9.5. Ordering chart accessories"** on page 27 or separate data sheet **Type 2518** ▶
- Stainless steel hollow screws are available on request.

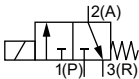
Circuit function	Variant	Pressure port P	Working port A (banjo bolt)	banjo bolt [mm]	Q _{Nn} value air [l/min]	Power consumption [W]	Pressure range [bar]	Material banjo bolt	Article no.		
									024/DC [V/Hz]	024/50 [V/Hz]	230/50 [V/Hz]
With FKM seal and manual override											
CF C 3/2-way solenoid valve Direct-acting Normally closed 	BJ01	G 1/8	G 1/8	1,5	75	8	0...16	Brass	20098150 ☒	389539 ☒	389541 ☒
	BJ01	G 1/8	G 1/8	2,0	120	8	0...10	Brass	20098151 ☒	389545 ☒	389547 ☒
	BJ02	G 1/4	G 1/4	1,5	75	8	0...16	Brass	334869 ☒	389542 ☒	389543 ☒
	BJ02	G 1/4	G 1/4	2,0	120	8	0...10	Brass	334870 ☒	389548 ☒	389550 ☒
	BJ03	NPT 1/4	G 1/8	1,5	75	8	0...16	Brass	o. r.	o. r.	o. r.
	BJ03	NPT 1/4	G 1/8	2,0	120	8	0...10	Brass	o. r.	o. r.	o. r.
	BJ04	NPT 1/4	G 1/4	1,5	75	8	0...16	Brass	o. r.	o. r.	o. r.
	BJ04	NPT 1/4	G 1/4	2,0	120	8	0...10	Brass	o. r.	o. r.	o. r.
	BJ05	G 1/4	G 1/8	1,5	75	8	0...16	Brass	20058931 ☒	o. r.	o. r.
	BJ05	G 1/4	G 1/8	2,0	120	8	0...10	Brass	20034151 ☒	o. r.	o. r.
	BJ06	G 1/8	G 1/4	1,5	75	8	0...16	Brass	o. r.	o. r.	o. r.
	BJ06	G 1/8	G 1/4	2,0	120	8	0...10	Brass	o. r.	20051143 ☒	20043155 ☒
	BJ07	NPT 1/8	G 1/8	1,5	75	8	0...16	Brass	o. r.	o. r.	o. r.
	BJ07	NPT 1/8	G 1/8	2,0	120	8	0...10	Brass	o. r.	o. r.	o. r.

o. r. = on request

DTS 1000011035 EN Version: AA Status: RL (released | freigegeben | valide) printed: 22.05.2026

ATEX/IECEX m cable variant

Note:

The maximum medium temperature must never exceed the permitted temperature class (T4: +135 °C, T5: +100 °C, T6: +85 °C) minus 5 K.

Circuit function	Port connection	Orifice	K _v value water	Voltage/frequency	Coil power	Pressure range	Body material	Article no. with manual override			
		[mm]	[m³/h]	[V/Hz]	[W]	[bar]					
Ex m II T4, with FKM seal and sub-base (SFB) connection with 3 m moulded cable, approved for block mounting, ambient temperature from -10 °C...+40 °C											
CF C 3/2-way solenoid valve Direct-acting Normally closed 	Sub-base (SFB)	1.5	0.07	024/UC	7	0...10	PA	364568 ☒			
				230/UC				352017 ☒			
		Sub-base (SFB)	2.0	0.11	024/UC		7	0...6	Brass	351967 ☒	
					230/UC					364570 ☒	
					024/UC	7	Brass	351981 ☒			
					230/UC			351990 ☒			

Circuit function	Port connection	Orifice	K _v value water	Voltage/frequency	Coil power	Pressure range	Body material	Article no. without manual override	Article no. with manual override				
		[mm]	[m³/h]	[V/Hz]	[W]	[bar]							
Ex m II T4, with FKM seal and threaded connection with 3 m moulded cable, approved for single mounting, ambient temperature from -10 °C...+55 °C													
CF C 3/2-way solenoid valve Direct-acting Normally closed 	G 1/8	2.0	0.11	024/UC	9	0...10	Brass	351966 ☒	351979 ☒				
				230/UC				351982 ☒	352034 ☒				
				G 1/4	0.11		0.11	024/UC	9	0...10	Stainless steel	351988 ☒	o. r.
								230/UC				352026 ☒	o. r.
	G 1/8	2.5	0.16			024/UC		9	Brass		351969 ☒	351970 ☒	
						230/UC					351978 ☒	352006 ☒	
	G 1/4	0.16	0.16	024/UC	9	0...6	Stainless steel	351963 ☒	o. r.				
				230/UC				352002 ☒	o. r.				
					024/UC	9	Brass	o. r.	o. r.				
					230/UC			o. r.	o. r.				
					024/UC	9	Brass	351995 ☒	352000 ☒				
					230/UC			364572 ☒	o. r.				
CFT 3/2-way solenoid valve Direct-acting Flow direction optional Normally closed 	G 1/8	1.5	0.07	024/UC	9	0...7	Brass	364573 ☒	o. r.				
				230/UC				o. r.	o. r.				
				G 1/4	0.07		0.07	024/UC	9	0...7	Stainless steel	352009 ☒	o. r.
								230/UC				351989 ☒	o. r.
	G 1/8	1.5	0.07			024/UC		9	Brass		o. r.	o. r.	
						230/UC					o. r.	o. r.	
					024/UC	9	Stainless steel	351994 ☒	o. r.				
					230/UC			o. r.	o. r.				

o. r. = on request

DTS 1000011035 EN Version: AA Status: RL (released | freigegeben | valide) printed: 22.05.2026

ATEX/IECEX m terminal box variant

Note:

The maximum medium temperature must never exceed the permitted temperature class (T4: +135 °C, T5: +100 °C, T6: +85 °C) minus 5 K.

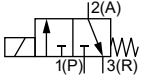
Circuit function	Port connection	Orifice	K _v value water	Voltage/frequency	Coil power	Pressure range	Body material	Article no. with manual override		
		[mm]	[m³/h]	[V/Hz]	[W]	[bar]				
Ex m II T4, with FKM seal and sub-base (SFB), approved for block mounting, ambient temperature from -10 °C...+40 °C										
CFC 3/2-way solenoid valve Direct-acting Normally closed 	Sub-base (SFB)	1.5	0.07	024/UC	7	0...10	PA	352062		
				230/UC				364576		
		Sub-base (SFB)	2.0	0.11	024/UC		7	0...6	Brass	o. r.
					230/UC					o. r.

o. r. = on request

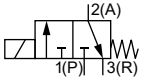
Circuit function	Port connection	Orifice	K _v value water	Voltage/frequency	Coil power	Pressure range	Body material	Article no. without manual override	Article no. with manual override			
		[mm]	[m³/h]	[V/Hz]	[W]	[bar]						
Ex m II T4, with FKM seal and threaded connection, approved for single mounting, ambient temperature form -10 °C...+55 °C												
CFC 3/2-way solenoid valve Direct-acting Normally closed 	G 1/8	2.0	0.11	024/UC	9	0...10	Brass	352001	351983			
				230/UC				352005	364614			
				G 1/4	0.11		024/UC	9	0...10	Brass	351998	o. r.
							230/UC				364581	o. r.
	G 1/8	2.5	0.16	024/UC	9	0...6	Brass	351992	351980			
				230/UC				364587	352071			
				G 1/4	0.16		024/UC	9	0...6	Brass	352067	o. r.
							230/UC				352041	o. r.
	G 1/8	1.5	0.07	024/UC	9	0...7	Brass	364595	o. r.			
				230/UC				364598	o. r.			
				G 1/4	0.07		024/UC	9	0...6	Brass	364600	364615
							230/UC				364603	364618
G 1/8	1.5	0.07	024/UC	9	0...7	Brass	364606	o. r.				
			230/UC				o. r.	o. r.				
			G 1/4	0.07		024/UC	9	0...7	Brass	o. r.	o. r.	
						230/UC				o. r.	o. r.	
G 1/8	1.5	0.07	024/UC	9	0...7	Stainless steel	364610	o. r.				
			230/UC				364611	o. r.				

o. r. = on request

DTS 1000011035 EN Version: AA Status: RL (released | freigegeben | valide) printed: 22.05.2026

ATEX/IECEX ia variant

Note:

The maximum medium temperature must never exceed the permitted temperature class (T4: +135 °C, T5: +100 °C, T6: +85 °C) minus 5 K.

Circuit function	Port connection	Orifice [mm]	Q _{Nn} value air [l/min]	Pressure range [bar]	Body material	Article no.
Ex ia II T6 with FKM seal only for approved single mounting, cable plug acc. to DIN EN 175 301 - 803 form A, ambient temperature from -10 °C...+60 °C for T6, -10...-75 °C for T5						
CF C 3/2-way solenoid valve Direct-acting Normally closed 	Bürkert sub-base (SFB)	0.9	30	Vac. to 10	Stainless steel	20003982
	G 1/8					394532
	Bürkert sub-base (SFB)	G 1/8	Brass	394531		
				394530		

Further variants on request	
Additional Orifice: 1.2 mm, 3.0 mm	Voltage Non-standard voltages
Approval Further information can be found in chapter "3. Approvals and conformities" on page 5.	Material Epoxy coil according to form A Seal material EPDM

9.5. Ordering chart accessories

Single manifold

Note:

Refer to chapter **"5.6. Single manifold"** on page 17 for more order information.

Multiple manifold

Note:

Refer to chapter **"5.7. Multiple manifold"** on page 17 for more order information.

Cable plug Type 2518, form A according to DIN EN 175301 - 803

Note:

- Dimensions in mm
- For further variants see data sheet **Type 2518**

Cable plug	Dimensions	Variant	Voltage	Article no.
		Without wiring (AC/DC)	0...250 V AC/DC	314802
		With LED (AC/DC)	12...24 V AC/DC	314812
		With LED and varistor (AC/DC)	12...24 V AC/DC	314820
		With rectifier, LED and varistor	12...24 V AC/DC	314816

DTS 1000011035 EN Version: AA Status: RL (released | freigegeben | valide) printed: 22.05.2026

Cable plug Type 2509, form A according to DIN EN 175301 - 803

Note:

- Dimensions in mm
- Without wiring (standard)
- The cable plug Type 2509 meets the requirements of ATEX Cat. 3 GD in assembly with a Bürkert solenoid valve.
- The cable plug Type 2509 meets the requirements of UL Listed (UL 429) in assembly with a Bürkert solenoid valve.
- Refer to data sheet **Type 2509** ▶ for more information about the cable plug.

Cable plug	Dimensions	Variant	Voltage	Article no.
		Without wiring	0...250 V AC/DC	137943

Cable glands for ATEX/IECEX terminal box

Note:

- A polyamide cable gland is included in the scope of delivery. A nickel-plated brass variant can be ordered for a surcharge.
- Refer to **"8.1. Cable glands for ATEX/IECEX terminal box"** on page 20 for more information about Ex cable glands.
- Refer to **"8.2. Special tool to turn the terminal box"** on page 20 for more information about special tool.

Description	Article no.
Ex cable gland, nickel-plated brass, 6...13 mm ¹⁾	773278
Ex cable gland, polyamide, 7...13 mm ¹⁾	773277
Set SC02-AC10: special tool ²⁾ incl. service manual	293488

1.) Cable diameter

2.) Not included in the scope of delivery of the valve

DTS 1000011035 EN Version: AA Status: RL (released | freigegeben | valide) printed: 22.05.2026